



Please use your phone camera to scan the QR code to Visit DayOptics website or Follow us on LinkedIn

en.dayoptics.com | 



LASER COMPONENTS

New Recommendations

Head Office

Hunan Dayoptics, Inc.

Add: 008, Jinshui West Road, Ningxiang Jinzhou New District, Changsha, 410600, Hunan, China

Tel: +86 731-8705 1588

Branch Office

Fujian Dayoptics, Inc.

Add: Building 6, No. 66 Anxia Road, Nanyu Gaoqi Industrial Park, Fuzhou High-tech Zone, Fuzhou, 350109, Fujian, China

Tel: +86 591-8321 5681



ABOUT DAYOPTICS

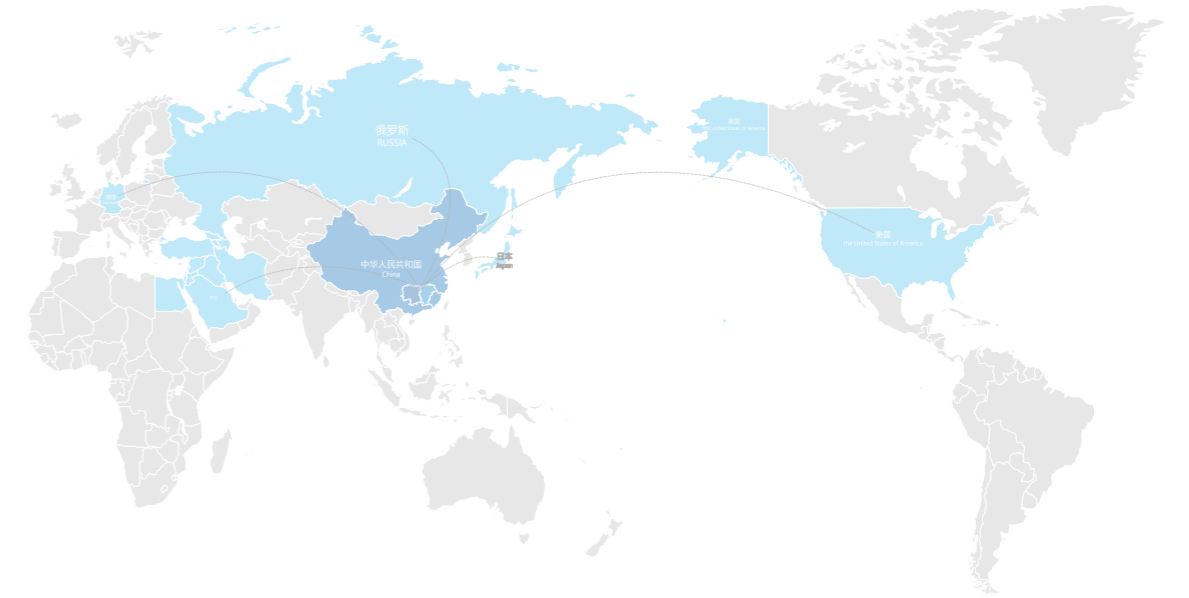

Founded in 2005, DayOptics has always focused on R&D and high-quality manufacturing or photonics products. Our products cover precision optical components, optical assemblies, laser components, and optical systems, widely used in many fields such as lasers, optical communications, biomedicine, AI (artificial intelligence), IOT (Internet of Things), 5G, semiconductors, and defense. The products have been exported to USA, Japan, EU, ASEAN, the Middle East and other countries and regions.

With the spirit of "pursuing perfection and excellence in innovation", DayOptics pushes the boundaries of key technologies, establishes precision manufacturing platforms, and provides one-stop optical solutions for domestic and foreign customers.



Founded in
2005



Delivered to
50+ countries



Cooperating
partners 10,000+

COMPANY STRENGTH: TEST AND MEASUREMENT



Laser acousto-optic modulation performance test platform:
Guaranteeing Product Performance



QCS spot test platform:
Accurate Measurement and Control of Laser Spot Size

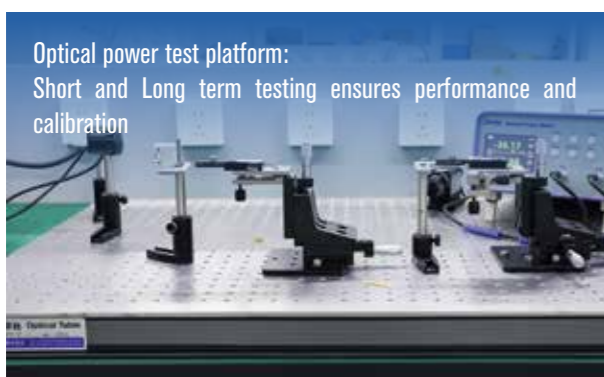

Optical power test platform:
Short and Long term testing ensures performance and calibration



Laser Damage Threshold Test:
Ensuring Long Life times and providing peace of mind



IBS Coating:
High Damage Threshold Laser Coatings



ZYGO Interferometer:
Precision Measurement of Product Surface Flatness



Ultrasonic Cleaning:
Efficient Cleaning and More Reliable



Cleanroom Assembly:
Ensuring the highest quality products each time

UV F-THETA LENSES



The 355nm UV F-theta lenses focus the collimated laser beam on one point to increase the energy density of the laser beam. When the direction of the incident beam changes, F-theta lenses can still maintain a spot with the same relative size and energy density, ensuring process efficiency is maintained.

FEATURES

- Low insertion loss
- High damage threshold
- High beam quality

APPLICATIONS

- Ultra-fine laser marking
- Laser cutting, welding, etc.
- Optical Scanning systems

SPECIFICATIONS

Parameter	Unit	Value
Design wavelength	nm	340-360 nm
Effective focal length	mm	100 mm
Max. input beam-Ø	mm	10.0 mm
Working distance	mm	130 mm
Scan area	/	35 mm×35 mm (Or customize 50mm×50mm, 100mm×100mm)
Max. telecentricity tolerance	°	<1°
Transmission rate	%	> 94%
Lens material	/	Fused silica
Suitable for ultra-short pulse	/	Yes
LIDT	/	0.2J/cm ² @15ps, 355nm, 800kHz(estimated value)
Weight	kg	2.45 kg

1064NM LASER F-THETA LENSES



The 1064nm laser F-theta lenses provided by DayOptics adopts high-quality optical design and modern manufacturing technology. They are widely used in the laser marking industry. It can provide a high-quality flat field effect and minimal geometric distortion to ensure that the laser spot reaches the diffraction limit.

FEATURES

- Small size
- Flexible applications
- 99.7% antireflection coating
- Longer life time

APPLICATIONS

- Laser marking/engraving
- Laser cutting/cleaning, etc.

Parameter	GCJ-I-F100	GCJ-I-F160	GCJ-I-F210	GCJ-I-F254
Working wavelength	1064 nm	1064 nm	1064 nm	1064 nm
Effective focal length	100 mm	160 mm	210 mm	254 mm
Working distance	120 mm	185 mm	240 mm	292.4 mm
Tube working distance	115 mm	181 mm	236 mm	288.4 mm
Field of view	±25°	±27.7°	±27.7°	±27.7°
Scan area	70 mm×70 mm	110 mm×110 mm	150 mm×150 mm	175 mm×175 mm
Input beam diameter @1/e ²	≤Φ10 mm	≤Φ10 mm	≤Φ10 mm	≤Φ10 mm
Galvo M 2 to lens	15.5 mm	15 mm	16.5 mm	20 mm
Galvo M 2 to lens tube	8.9 mm	9.4 mm	10.65 mm	13.8 mm
Focused spot@1/e ²	center/edge 12/29μm	center/edge 20/34μm	center/edge 19/35μm	center/edge 14/30μm
Lens barrel outer diameter	Φ63 mm	Φ59 mm	Φ59 mm	Φ59 mm
Metric, Imperial or custom available	Customized	Customized	Customized	Customized
Total length of lens barrel	36.5 mm	24.1 mm	24.15 mm	28 mm
Protective window	optional	optional	optional	optional
Transmittance (with window mirror)	≥97.6%	≥97.6%	≥97.6%	≥97.6%
Transmittance (without window mirror)	≥98.2%	≥98.2%	≥98.2%	≥98.2%

SPECIFICATIONS

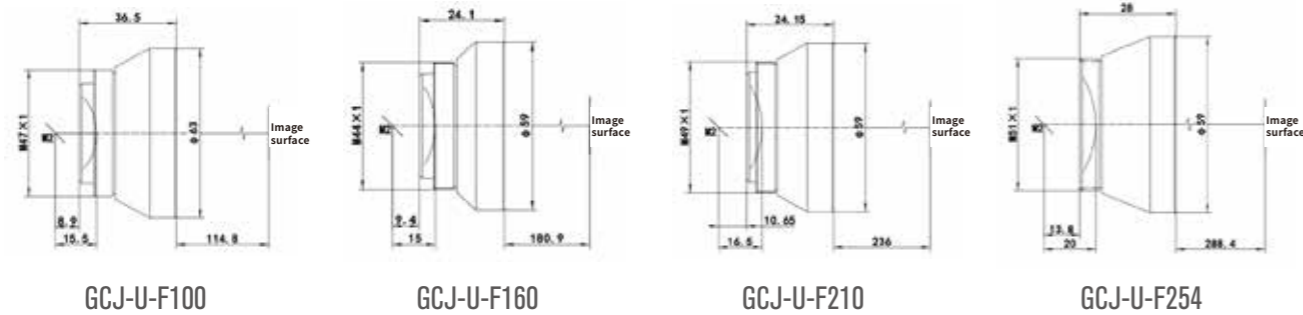

VARIABLE BEAM EXPANDERS



Laser variable beam expanders are suitable for optical systems that require different magnifications and precise control of laser beam divergence or convergence. The variable beam expanders designed by DayOptics deliver beam expansion and focus compensation by rotating the adjustment ring outside the lens barrel. When the Gaussian beam size required by the user is reached, the screws can be tightened to fix the current magnification and focus configuration.

FEATURES

- Used for precise control of laser beams magnification
- In diverging or converging optical systems
- Beam expansion and focus compensation

APPLICATIONS

Ultrafast picosecond/femtosecond lasers

SPECIFICATIONS

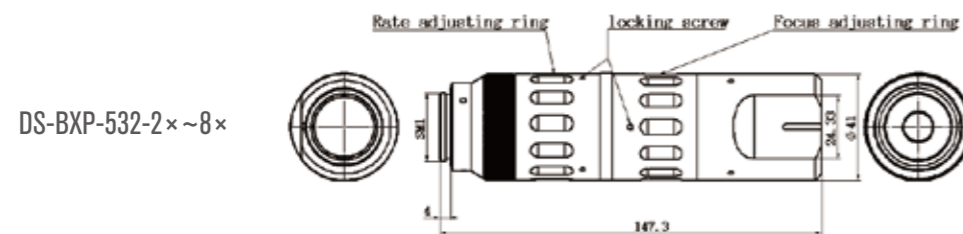
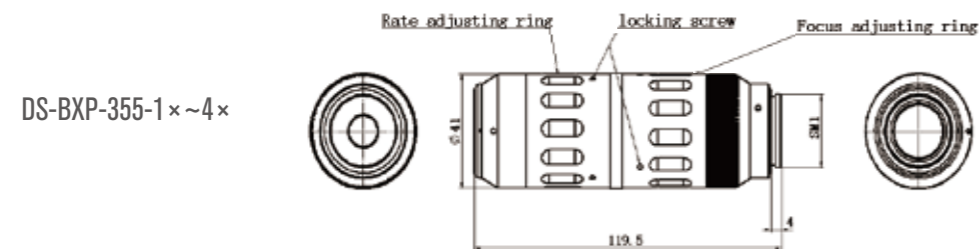

Parameter	DS-BXP-355-1×~4×	DS-BXP-532-2×~8×
Beam expansion factor	1×~4×	2×~8×
Lens material	CN7980 OF	CN7980 OF
Lens transmittance	> 97%@355nm	> 97%@532nm
Single lens reflectance	R < 0.1%@355nm&R < 0.2%@345~365nm	R < 0.1%@532nm&R < 0.2%@522~542nm
Laser damage threshold (10ns, 10Hz)	> 0.8J/cm ² @355nm, 10ns, 10Hz	> 0.75J/cm ² @532nm, 10ns, 10Hz
Housing size	41.5×120mm (SM1 Thread type)	41.5×147.5mm (SM1 Thread type)
Mounting thread	SM1 metric (Optional)	SM1 metric (Optional)

Parameter	Magnification	Maximum incident beam diameter	Wavefront difference
DS-BXP-355-1×~4×	1×	Φ4 mm	< λ/4@632.8 nm
	2×	Φ5.5 mm	< λ/4@632.8 nm
	3×	Φ3 mm	< λ/4@632.8 nm
	4×	Φ3 mm	< λ/4@632.8 nm
DS-BXP-532-2×~8×	2×	Φ5 mm	< λ/4@632.8 nm
	3×	Φ5 mm	< λ/4@632.8 nm
	4×	Φ4 mm	< λ/4@632.8 nm
	5×	Φ3 mm	< λ/4@632.8 nm
	6×	Φ2.5 mm	< λ/4@632.8 nm
	7×	Φ2 mm	< λ/4@632.8 nm
	8×	Φ2 mm	< λ/4@632.8 nm

INTEGRATED MICROSCOPE LENSES



The familiar microscope lens can achieve magnification of small objects and is widely used in the biomedical field, such as in vitro diagnostic equipment, laboratory equipment, clinical application, and blood cell analysis. The DayOptics customized miniaturized design can be easily integrated into various equipment for maximum performance in a compact package.

FEATURES

- Small size
- Cost efficient
- Suitable for OEM applications

APPLICATIONS

Many applications including, in vitro diagnostic equipment: used for blood cell analysis of blood, urine sediment, feces, sperm quality and cytopathology.
 Laboratory equipment: particle counting, cell culture experiments
 Multiple Clinical Applications.

SPECIFICATIONS

Optical Parameters	
Magnification	17X
Working Distance (mm)	3.4
CCD Size (mm)	9 (1/1.8")
Distortion (%max)	0.3%
Numerical Aperture NA	0.38
Resolution (um)	0.7
Depth of Field (um)	3.7
Mechanical Dimensions	
Camera Interface	C Interface
Overall Length (mm)	90
Maximum Diameter (mm)	30
Field Of View	
1/1.8" (7.13*5.37)	0.356*0.269
1/2" (6.4*4.8)	0.32*0.24

30W 1064NM QCS FIBER CONNECTORS



QCS fiber connector is a compact pigtail collimated output component specially designed for direct semiconductor and fiber lasers. It can achieve collimated beam expansion or long-focus, low-reflection spatial emission of laser beams.

FEATURES

- Good beam quality
- Stable and reliable

APPLICATIONS

- Semiconductor laser
- Fiber laser

SPECIFICATIONS

Item	Unit	Min.	Typ.	Max.	Comments
Central wavelength	nm		1064		
Bandwidth	nm	1054		1074	
Maximum output power	W		30		
Transmittance	%	98			
Spot size	mm	5		7	
Spot roundness	%	92			
M2 deterioration rate	%			10	
Output beam off axis	μm			100	
Divergence angle	mrad			0.5	

Item	Unit	Min.	Typ.	Max.	Comments
Fiber type	/	YOFC 20/130 DC	YOFC 20/130 DC	YOFC 20/130 DC	
Armor cable length	m	NO	NO	NO	
Bare fiber length	m		1.5		up to 2m
Loose tube diameter medium	mm		0.9		
Loose tube length	m	0.6	0.7	0.8	
Operating temperature	°C	0		50	
Storage temperature	°C	-5		70	
Structural part outer diameter	mm			15	
Structural member length	mm			75	

CONVENTIONAL OUTPUT - FREE SPACE ISOLATORS



Consists of a collimator, a birefringent crystal, a Faraday rotator, a half-wave plate (or polarizing plate) and a beam expander. The output beam has the characteristics of good beam quality and small divergence angle.

■ FEATURES

- Low insertion loss
- High stability
- Excellent isolation

■ APPLICATIONS

- Fiber laser
- Fiber optic sensor
- Laser processing equipment, etc.

SPECIFICATIONS (STANDARD PRODUCT)

Power Range	Wavelength	Spot diameter	Transmittance	Peak isolation
1-50 W	980-2000 nm	0.4-10 mm	>93%*>90%*	>33 dB*>45 dB**
50-120 W	980-2000 nm	0.4-10 mm	>93 %	>33 dB
200-350 W	1064 nm	1-10 mm	>93 %	>33 dB

MINI OUTPUT - FREE SPACE ISOLATORS



Consists of a collimator, birefringent crystal, Faraday rotator, half-wave plate (or polarizing plate) and beam expander. The output beam has the characteristics of good beam quality and small divergence angle.

FEATURES

- Low insertion loss
- High stability
- High isolation

APPLICATIONS

- Fiber laser
- Fiber optic sensor
- Laser processing equipment, etc.

SPECIFICATIONS

Parameter	Unit	Min.	Typ.	Max.
Wavelength	nm	1054	1064	1074
Isolation (at 23°C, λ_c)	dB	30	-	-
Isolation (at 23°C, bandwidth)	dB	28	-	-
Transmittance (at 23°C, λ_c)	%	93	-	-
Transmittance (at 23°C, @652-665nm)	%	25	-	-
Ellipticity	%	93	-	-
Output Beam Diameter (4σ)	mm	6.5		8
Beam Divergence (far field)	mard			0.3
Beam Pointing Error	deg			0.5

Parameter	Unit	Min.	Typ.	Max.
M2 Degradation	%			10
Return loss	dB	50		
Fiber Type	/	YOFC, GDF-20/130-DC	YOFC, GDF-20/130-DC	YOFC, GDF-20/130-DC
Fiber NA	/	0.07	0.08	0.09
Jacketed Cable Diameter	mm	10.3	10.5(black)	10.7
Jacketed Cable length	m	1.1	1.2	1.3
Armed Cable Diameter	mm		3.0(blue)	
Armed Cable length	m	1.26	1.28	1.3
Buffer Tube Diameter	mm	-	0.9	-
Buffer Tube Out of Armed Cable	mm	70	100	130
Fiber Length Out of Armed Cable	cm	100		

100W FREE SPACE ISOLATORS

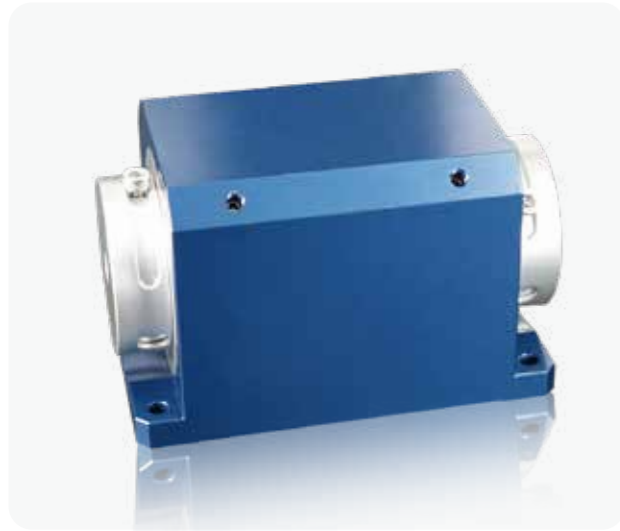

The free space isolator is composed of a birefringent crystal (or polarizer), a Faraday rotator and a half-wave plate. It is used in fiber lasers and can effectively stop back reflections.

FEATURES

- Low insertion loss
- High extinction ratio

APPLICATIONS

- Laser sensing system
- Ultrafast laser system
- Solid State lasers, amplifiers

SPECIFICATIONS

Parameter	Unit	Value
Center Wavelength (λ_c)	nm	1060 or specified
Peak Transmission (λ_c , 23°C)	%	> 95
Peak Isolation (λ_c , 23°C)	dB	> 33
Aperture	mm	5
Optical Average Power	W	100
Operating Temperature	°C	+ 10 to + 30
Storage temperature	°C	0 to + 60

1064NM POLARIZATION MAINTAINING INLINE ISOLATORS

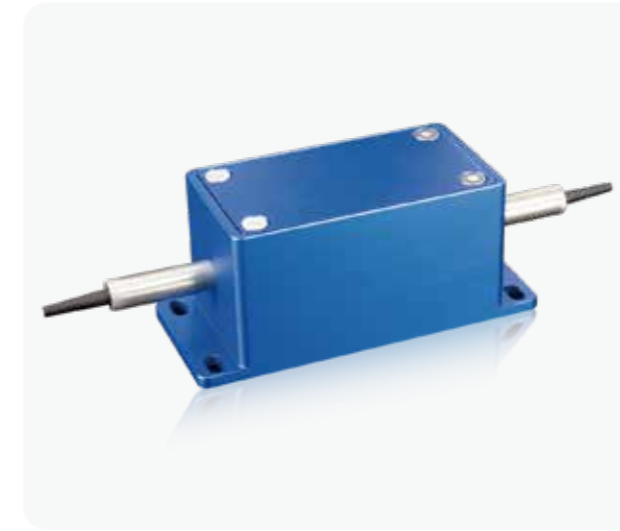

A micro-optical device that ensures one-way transmission of light beams and prevents damage to the light source caused by reflected light in the optical path. It uses polarization-maintaining optical fiber to connect to the micro-optical system. Polarization-maintaining fiber isolators commonly use the Faraday effect to allow light in a specific direction to pass through, but light in the opposite direction cannot pass through.

FEATURES

- Excellent isolation
- High return loss and low insertion loss
- Stable and reliable

APPLICATIONS

- Ytterbium-doped fiber amplifier
- Intensive optical wave multiplexing system
- Optical coherence detection
- Laser sensing
- Optical fiber communication

SPECIFICATIONS

Parameter	Unit	Value
Center Wavelength (λ_c)	nm	1060 or specified
Maximum Insertion Loss (λ_c , 23°C)	dB	0.7
Peak Isolation (λ_c , 23°C)	dB	30
Minimum Extinction Ratio	dB	22
Minimum Return Loss	dB	50
Maximum Optical Average Power	W	30
Fiber Type	-	PM980 or PM 10/125
Operating Temperature	°C	+ 10 to + 30
Storage temperature	°C	0 to + 60

INLINE CIRCULATORS

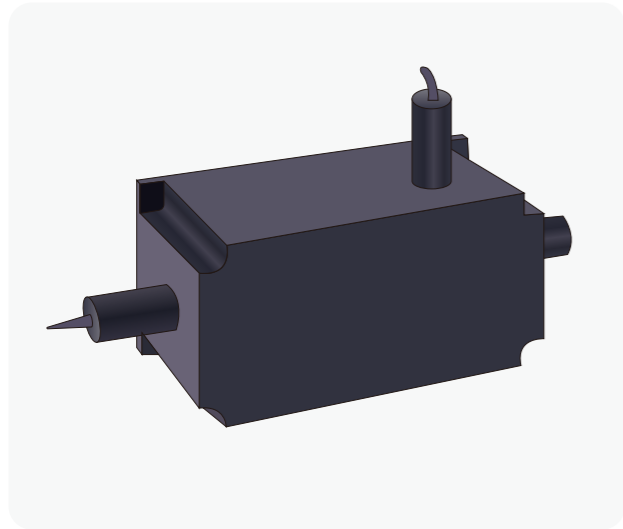

Optical circulators are one-way three-port devices with unidirectional transmission that allow light to propagate in a specific direction only. Circulators can be divided into non-polarization-maintaining circulators and polarization-maintaining circulators.

FEATURES

- High isolation
- High return loss and low insertion loss
- Stable and reliable

APPLICATIONS

- Ytterbium-doped fiber amplifier
- Intensive optical wave multiplexing system
- Optical coherence detection
- Laser sensing
- Optical fiber communication

SPECIFICATIONS (STANDARD PRODUCT)

Withstand power	Extinction ratio*	Insertion Loss	Terminal's minimum crosstalk	Peak isolation
1 W	>18 dB	≤1.2 dB	≥45 dB	≥45 dB
50 W	>18 dB	≤1.2 dB	≥45 dB	≥45 dB

FARADAY ROTATORS

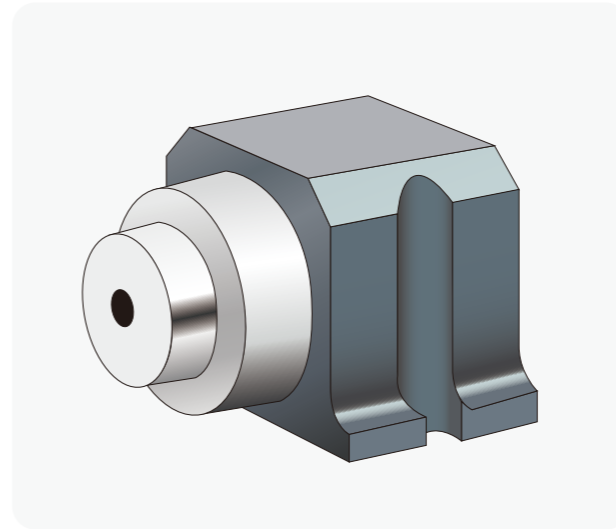

Faraday rotators provide uni-directional rotation while maintaining linear polarization of the beam. The plane of polarization will be rotated 45° when light transmits through the Faraday rotator in the forward direction and rotated additional 45° in the same relative direction with respect to magnetic field when light travels backwards from the reverse direction. This cumulative addition of 90 degrees of total rotation allows for rejection of the returning light.

FEATURES

- High reliability
- M² has little deterioration

APPLICATIONS

- Laser sensing system
- Ultrafast laser system
- OCT system
- Laser detection
- Solid state lasers, laser amplifiers

SPECIFICATIONS

Aperture (a)	Wavelength	Extinction ratio	Rotation angle	Withstand power	Transmission
2-12 mm	355-1080 nm	> 30 db	45±0.6°	100 W	> 98%
2-15 mm	1310-4500 nm	> 30 db	45±0.6°	100 W	> 98%

1064NM 100 MHZ FREE SPACE AOMs



The high-power, high-speed fiber acousto-optic modulator (AOM) is one of the core components of all-fiber laser. It has the advantages of ultra-high extinction ratio, low insertion loss and fast rise time, and can select and modulate pulse lasers.

FEATURES

- High damage threshold
- Fast rise time
- Low power consumption, high reliability

APPLICATIONS

- Solid state laser
- Laser cooling
- Fiber transmission test
- LiDAR

SPECIFICATIONS

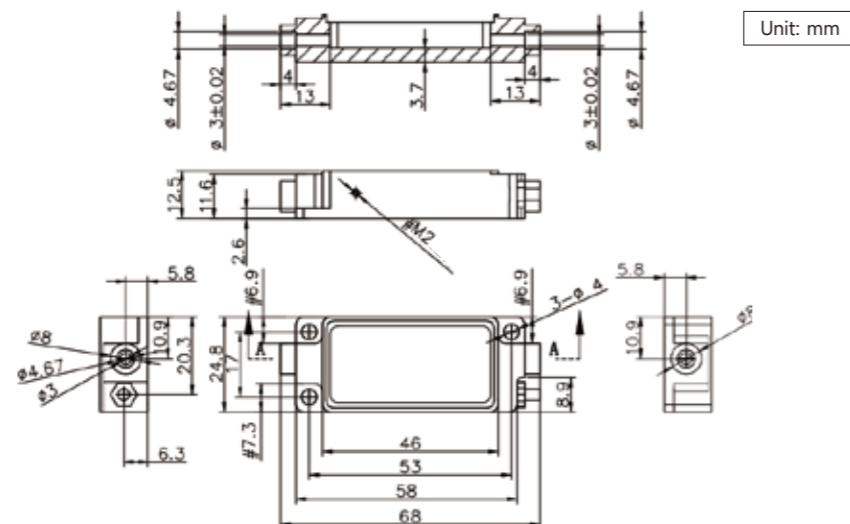

Item	Unit	Min.	Typ.	Max.
Material				TeO2
Wavelength	nm	880-1200	880-1200	880-1200
Average optical power	W		30	
Peak (pulse) optical power	kw		30	
Ultrasonic sound speed	m/s			4200
Diffraction efficiency	%	85		
Center frequency	MHz			100
Frequency shift	MHz			100
3dB bandwidth	MHz			±20
Clear aperture (length*width)	mm			3*0.6
RF power	W		2	
Rising time	ns		60	
Voltage standing wave ratio				1.3:1
Input resistance	Ω			50
Deflection angle	mrad			25.3
Device interface				SMA
Operating temperature	°C			-10~60
Storage temperature	°C			-40~70

1064NM 200MHZ POLARIZATION-MAINTAINING AOMs



1064nm, 200MHz Polarization-maintaining AOM (acousto-optic modulator) is specially developed for the requirements of optical sensing. It has the advantages of small size, low power consumption, fast rise time, good modulation pulse shape (small overshoot), good pulse repeatability (small repetition period jitter), etc., and can Integrated packaging of the modulator and driver facilitates system integration and can be widely used in various optical fiber sensing systems that require pulse modulation, such as ϕ -OTDR, BOTDR, and OFDR.

Item	Unit	Min.	Max	Typ.	Comments
Rise-time /Fall-time	ns		10		(10%-90%)
Frequency	MHz			200	
Frequency Shift	MHz			+200	Or -200 Customized
Radio Frequency Power	w		2.5		
VSWR				1.5:1	
Input Impedance	Ω			50	
Device Interface				SMA	
Fiber Type				PM980	
Fiber Length	m			1	
Fiber Termination				FC/APC	
Working temperature	$^{\circ}\text{C}$			-20~60	
Storage Temperature	$^{\circ}\text{C}$			-30~70	

FEATURES

- High damage threshold
- Withstand high power
- High extinction ratio

APPLICATIONS

- Optical sensing
- Lasers and fast switching

SPECIFICATIONS

Item	Unit	Min.	Max	Typ.	Comments
Material				TeO2	
Wavelength	nm	1000	1100	1064	
Average optical power handling	W		3		
Peak (pulse) optical power handling	kw		3		
Ultrasonic Velocity	m/s			4200	
Insertion Loss	dB		3		
PER	dB	18			
ER(1st order on /off)	dB	50			
Return Loss (RF ON)	dB	40			

ACOUSTO-OPTIC MODULATOR DRIVERS



The working principle is to use a modulator to pass the laser beam through the acousto-optic medium. When the acoustic wave propagates in the medium, it causes the light refractive index in the medium to change, which leads to the deflection, modulation or diffraction of the beam, and controls the intensity, frequency, phase and other parameters of the light modulation.

FEATURES

- High precision
- Broad frequency

APPLICATIONS

- Drive control of acousto-optical devices: deflectors, frequency shifters, filters

SPECIFICATIONS

Mode	QDQ-MG-100M-2.5W	QDQ-MG-200M-2.5W
Frequency (Mhz)	100	200
Frequency stability (ppm)	±30	±30
RF Power (W)	MAX 2.5	MAX 2.5
Modulation Mode	AM 0-1V/0-5V	AM 0-1V/0-5V
Output Resistance (Ω)	50	50
Operating Voltage (v)	+24VDC@380mA	+24VDC@380mA

GaN POWER SUPPLYS



Gallium nitride is used as the main material to generate laser energy. Gallium nitride power supply has the advantages of high efficiency, high power density and long life, so it is widely used in laser marking.

FEATURES

- Over-voltage protection
- Over current protection
- Short circuit protection
- PFC+LLC architecture
- High beam quality
- Small GaN chips and less heat
- Customized for laser marking

APPLICATIONS

- Laser marking

SPECIFICATIONS

Parameter	Unit
Four outputs	5V, 24V, +15V, -15V (customized)
Withstand voltage	IP-OP: 3000Vac; IP-PE:1500Vac; OP-PE: 500vdc
Working temperature	-40~70°C (-20~70°C for some models)
Startup time	<3s
Safety standard	GB4943/EN60950
EMC standard	IEC61000-4
Size (L*W*H)	145*83*32
Input parameters	AC100~264V, 50/60HZ
Efficiency	≥96%
Output power	≥ 330W/450W, or optional
No-load consumption	≤0.5 W

E-O Q-SWITCHES



Q-switch can quickly switch between producing very little or very high loss in the laser beam. This device is usually used in laser resonators to implement active Q-switching of lasers. This is a method of generating short, strong pulses with pulse lengths in the nanosecond range.

FEATURES

- Excellent electro-optical properties
- High damage threshold
- High transmittance
- Easy to adjust

APPLICATIONS

Q-switched laser

SPECIFICATIONS

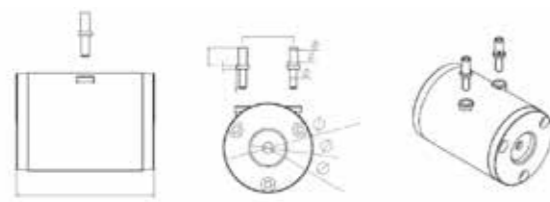

EOB-3A/4A/5A

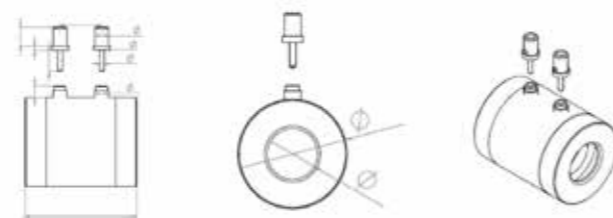

EOB-8Ga/10Ga/13Ga

Parameter	EOB-3A	EOB-4A	EOB-5A
External Dimension	Φ25.4×36 mm	Φ25.4×36 mm	Φ25.4×36 mm
Clear Aperture	Φ2.5 mm	Φ3.5 mm	Φ4.5 mm
Single Pass Optical Transmittance @1064nm	> 98%	> 98%	> 98%
Wavefront Distortion @633nm	/	/	/
Static Extinction Ratio@1064nm	> 1000:1	> 1000:1	> 1000:1
λ/4Voltage @1064nm	3250V	4350V	5500V
Capacitance	3.0pF	3.0pF	3.0pF
Laser Induced Damage Threshold	500MW/cm ² @1064nm,10ns,10Hz	500MW/cm ² @1064nm,10ns,10Hz	500MW/cm ² @1064nm,10ns,10Hz

Parameter	EOD-8Ga	EOD-10Ga	EOD-13Ga
External Dimension	Φ19×24 mm	Φ25.4×32 mm	Φ25.3×42.5 mm
Clear Aperture	Φ8 mm	Φ10 mm	Φ13 mm
Single Pass Optical Transmittance @1064nm	> 98%	> 98%	> 98%
Wavefront Distortion @633nm	< λ/8	< λ/8	< λ/8
Static Extinction Ratio@1064nm	> 5000:1	> 5000:1	> 5000:1
λ/4Voltage @1064nm	3200V+/-200V	3200V+/-200V	3200V+/-200V
Capacitance	4.5 pF	5.5 pF	8 pF
Laser Induced Damage Threshold	500MW/cm ² @1064nm,10ns,10Hz	500MW/cm ² @1064nm,10ns,10Hz	500MW/cm ² @1064nm,10ns,10Hz